

## 105-5.0

6 Watt, non isolated, single output buck converter

All parameters defined on  $T_a=25^{\circ}\text{C}$ ,  $I_{oNom} = 1.2 \text{ ADC}$  and  $U_{iNom} = 24\text{VDC}$

### ABSOLUTE MAXIMUM RATINGS

parameter	unit	typ
Input peak voltage	VDC	38.00

### THERMAL CHARACTERISTICS

parameter	min to max	typ
Ambient temperature range	$-40^{\circ}\text{C} / +85^{\circ}\text{C}$	
Max. case temperature for thermal shut down [ $^{\circ}\text{C}$ ]		+110 $^{\circ}\text{C}$
Storage temperature [device not in operation]	$-10^{\circ}\text{C} / +65^{\circ}\text{C}$	
Relative maximum humidity under storage		75% RH
Storage under worst conditions [in days]		25

### SPECIALS

parameter	unit	conditions	typ
Switching frequency	kHz		200
Efficiency at medium loads	%	0.5 $I_{oNom}$	91.00
Efficiency at full loads	%	$I_{oNom}$	91.00
MTTF	h	SN29500 @ 70 $^{\circ}$	1 800 000

### COMPLIANCE

parameter	fulfilled	notes
61000-4-6 [immunity against induced, conducted disturbances]	✓	
61000-6-4 [EMC - Emission standard for industrial environment]	✓	
55022<A	✓	

All technical and general information is provided in all conscience. However, completeness and accuracy cannot be guaranteed. Demke recommends to fully test the product in its determined application. Due to permanent improvements to our products, we reserve the right to change specifications at any time and without prior notification and without obligation to update products already supplied. This is a component for professional equipment manufacturers. Read the safety and installation instruction for proper use. Safety aspect and EMC-aspect must be considered in the end application.

## 105-5.0

6 Watt, non isolated, single output buck converter

### INPUT

parameter	unit	conditions	min	typ	max
Input voltage range	VDC	IoNom	7	24	36
No load input current	mA	UiNom		3	
Max. input current	A	UiNom		1	
Input start up voltage	VDC	UiNom		5.6	
Undervoltage lockout	VDC	UiNom		3.8	
Input current overshoot during soft start ramp up	%	IoNom		110	
Generated AC-ripple on the supply [BW=20MHz]	mVp-p	UiNom/loNom		50	
Generated HF-noise on the supply [BW=20MHz]	mVp-p	UiNom/loNom		60	
Typical input noise slew rate [BW=500MHz]	mVp-p	UiNom/loNom		25	

### OUTPUT

parameter	unit	conditions	min	typ	max
Output voltage	VDC	IoNom		5.0	
Minimum required load to obtain the specified output voltage	%	UiNom		0	
Generated AC-ripple on the output [BW=20MHz]	mVp-p	UiNom/loNom		60	
Generated HF-noise on the output [BW=20MHz]	mVp-p	UiNom/loNom		40	
Typical output noise slew rate [BW=500MHz]	mVp-p	UiNom/loNom		30	
Output voltage accuracy	%	IoNom		+/-1.50%	
Output voltage overshoot at initial switch-on	%	IoNom		overdamped	
Rated output power	W			6	

### CONTROL

parameter	unit	conditions	min	typ	max
Static line regulation	%	IoNom/UiMin...UiMax		0.05	
Static load regulation	%	IoMin...IoMax/UiNom		0.1	
Dynamic load change adjusting time	ms	LoadChange 10...90%		0.50	
Dynamic load change deviation to nominal output voltage	V	LoadChange 10...90%		0.10	
Maximum admissible capacitive load	uF	IoNom		4700	
Initial switch on time	ms	IoNom		13	
Softstart ramp up time	ms	IoNom		13	

All technical and general information is provided in all conscience. However, completeness and accuracy cannot be guaranteed. Demke recommends to fully test the product in its determined application. Due to permanent improvements to our products, we reserve the right to change specifications at any time and without prior notification and without obligation to update products already supplied. This is a component for professional equipment manufacturers. Read the safety and installation instruction for proper use. Safety aspect and EMC-aspect must be considered in the end application.

## 105-5.0

6 Watt, non isolated, single output buck converter

### MECHANICAL parameter

parameter	unit	
Overall dimensions	mm	32x20x10
Weight	g	14

Pin No.	Function	Electrical Determination
1	Vi+	Input voltage positive
10	Vi-/Vo-	Input and output voltage neg
11	Vo+	Output voltage positive
12	Vi-/Vo-	Input and output voltage neg
13	Vi-/Vo-	Input and output voltage neg
14	Vo+	Output voltage positive
15	Vi-/Vo-	Input and output voltage neg
24	Vi+	Input voltage positive

### Mechanical dimensions and Pin configuration

All dimensions in mm

Connector type: THT

Case: DIL24

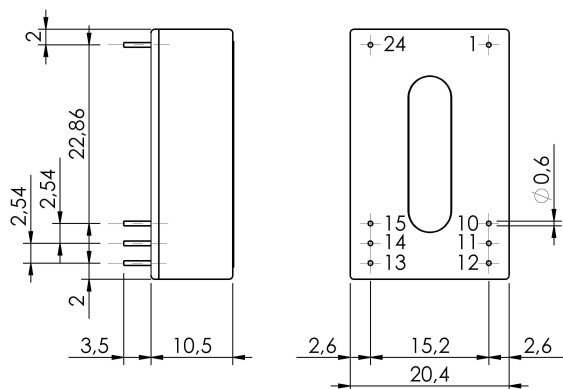

All technical and general information is provided in all conscience. However, completeness and accuracy cannot be guaranteed. Demke recommends to fully test the product in its determined application. Due to permanent improvements to our products, we reserve the right to change specifications at any time and without prior notification and without obligation to update products already supplied. This is a component for professional equipment manufacturers. Read the safety and installation instruction for proper use. Safety aspect and EMC-aspect must be considered in the end application.